

914 MACHINABLE GLASS CERAMICS

Vacuum Tight, High Resistance and Impact Strength

Precision Components Tooling - Fixturing

- Electrical Components
- Insulators
- R. F. Heating Fixtures
- Supports
- Brazing
- Soldering Fixtures
- Vacuum Components
- Prototype Hardware

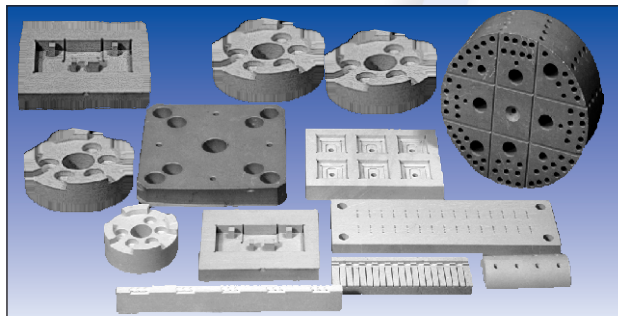
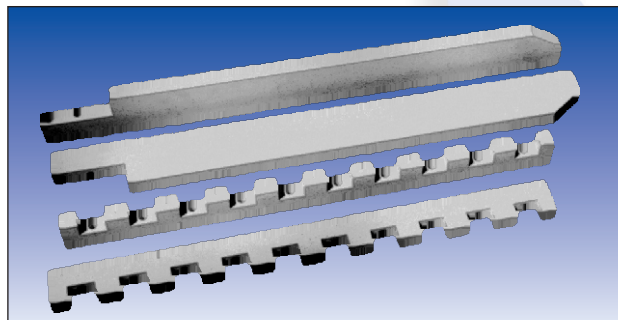

A dense and vacuum tight, Glass Ceramic Composite that is readily machinable on conventional equipment with standard cutting tools.

No post machining heat treatments are required.

Rescor™ 914 Glass Ceramic is inert to oxidizing and reducing atmospheres and usable to 1000°F maximum. Offers excellent mechanical and electrical properties and has a dielectric strength of 480 volts/mil.

Can be metallized and soldered.

Rescor™ 914's low thermal conductivity, high impact and mechanical strength make it an ideal high temp material.

Ideal for vacuum feed-throughs and for all electrical and vacuum needs.

Rescor™ 914 is low in cost and can be used instead of Macor™ (glass ceramic) if temperatures do not exceed 1000°F.

Full machining instructions included.

New, high temperature grade, Rescor™ 914HT will provide service to 1100°F and is available upon request.

Rescor™ Base	914 Glass Ceramic
Max Service Temp. (°F)	1000
Continuous Use Temp. (°F)	800
Mixed Density (gms/cc)	2.60
Thermal Cond. (BTU in / Hr. Ft ² °F)	2.80
Thermal Expansion (x 10 ⁻⁶ °F)	5.20
Compressive Strength (psi)	40,000
Flexural Strength (psi)	26,000
Dielectric Strength (volts/mil.)	480
Volume Resistivity (ohm-cm)	10 ¹⁴
Loss Factor (@ 1 MHZ)	0.01
Dielectric Constant (@ 1 MHZ)	7.50
Typical Tolerances Plates (in.)	+/- 0.015
Typical Tolerances Rod (in.)	+/- 0.005

Cat. No.	Plate Sizes	Price
914-01.....	1/16" x 12" x 18"	POR
914-04.....	1/8" x 9" x 12"	357.52
914-05.....	1/8" x 12" x 18"	612.76
914-09.....	1/4" x 9" x 12"	302.77
914-10.....	1/4" x 12" x 18"	515.78
914-15A.....	1/2" x 9" x 12"	388.32
914-15.....	1/2" x 12" x 12"	649.38
914-17A.....	3/4" x 9" x 12"	503.84
914-17.....	3/4" x 12" x 18"	858.65
914-19A.....	1" x 9" x 12"	654.22
914-19.....	1" x 12" x 18"	1,081.15

Cat. No.	Rod Sizes	Price
914-22.....	1/4" x 12"	91.20
914-25.....	1/2" x 12"	103.93
914-28.....	3/4" x 12"	128.01
914-31.....	1" x 12"	161.12
914-32.....	1-1/4" x 12"	293.57

Send Prints For Custom Machining Services